

# User's and Service Guide

## Agilent Technologies 85036B/E 75 $\Omega$ Type-N Calibration Kits

This manual applies directly to Agilent 85036B calibration kits with serial number prefix 3514A, and Agilent 85036E calibration kits with serial number prefix 3142A. The calibration devices in this kit are individually serialized. Record the device serial numbers in the table provided in this manual. (See "Recording the Device Serial Numbers" in Chapter 1.)



**Manufacturing Part Number: 85036-90016**

**Printed in USA**

**Print Date: December 2006**

Supersedes: June 2002

© Copyright 1995, 2001, 2002, 2006 Agilent Technologies, Inc. All rights reserved.

---

## Documentation Warranty

THE MATERIAL CONTAINED IN THIS DOCUMENT IS PROVIDED "AS IS," AND IS SUBJECT TO BEING CHANGED, WITHOUT NOTICE, IN FUTURE EDITIONS. FURTHER, TO THE MAXIMUM EXTENT PERMITTED BY APPLICABLE LAW, AGILENT DISCLAIMS ALL WARRANTIES, EITHER EXPRESS OR IMPLIED WITH REGARD TO THIS MANUAL AND ANY INFORMATION CONTAINED HEREIN, INCLUDING BUT NOT LIMITED TO THE IMPLIED WARRANTIES OF MERCHANTABILITY AND FITNESS FOR A PARTICULAR PURPOSE. AGILENT SHALL NOT BE LIABLE FOR ERRORS OR FOR INCIDENTAL OR CONSEQUENTIAL DAMAGES IN CONNECTION WITH THE FURNISHING, USE, OR PERFORMANCE OF THIS DOCUMENT OR ANY INFORMATION CONTAINED HEREIN. SHOULD AGILENT AND THE USER HAVE A SEPARATE WRITTEN AGREEMENT WITH WARRANTY TERMS COVERING THE MATERIAL IN THIS DOCUMENT THAT CONFLICT WITH THESE TERMS, THE WARRANTY TERMS IN THE SEPARATE AGREEMENT WILL CONTROL.

---

## Assistance

Product maintenance agreements and other customer assistance agreements are available for Agilent products.

For assistance, refer to "Contacting Agilent" on page 4.

---

## Printing Copies of On-Line Documentation

To print copies of documentation from the Web, download the PDF file from the Agilent web site:

- Go to <http://www.agilent.com>. Enter the document's part number (located on the title page) in the **Search** box.
- Click **Search**.
- Click on the hyperlink for the document.
- Click the printer icon located in the tool bar.

**1. General Information**

Calibration Kit Overview . . . . .	1-2
Kit Contents . . . . .	1-2
Calibration Definitions . . . . .	1-3
Equipment Required but Not Supplied . . . . .	1-3
Incoming Inspection . . . . .	1-4
Recording the Device Serial Numbers . . . . .	1-6
Calibration Kits Documented in this Manual . . . . .	1-7
Calibration Kit History . . . . .	1-7
Clarifying the Terminology of a Connector Interface . . . . .	1-8
Preventive Maintenance . . . . .	1-8

**2. Specifications**

Environmental Requirements . . . . .	2-2
Temperature—What to Watch Out For . . . . .	2-2
Mechanical Specifications . . . . .	2-3
Supplemental Mechanical Characteristics . . . . .	2-3
Electrical Specifications . . . . .	2-4
Certification . . . . .	2-4

**3. Use, Maintenance, and Care of the Devices**

Electrostatic Discharge . . . . .	3-2
Visual Inspection . . . . .	3-3
Look for Obvious Defects and Damage First . . . . .	3-3
Inspect the Mating Plane Surfaces . . . . .	3-3
Cleaning Connectors . . . . .	3-4
Connections . . . . .	3-6
How to Make a Connection . . . . .	3-6
How to Separate a Connection . . . . .	3-9
Handling and Storage . . . . .	3-10

**4. Performance Verification**

Introduction . . . . .	4-2
How Agilent Verifies the Devices in This Kit . . . . .	4-2
Recertification . . . . .	4-3
How Often to Recertify . . . . .	4-3
Where to Send a Kit for Recertification . . . . .	4-3

**5. Troubleshooting**

Troubleshooting Process . . . . .	5-2
Where to Look for More Information . . . . .	5-3
Returning a Kit or Device to Agilent . . . . .	5-3
Contacting Agilent . . . . .	5-4

**6. Replaceable Parts**

---

# Contents

Introduction ..... 6-2

## **A. Standard Definitions**

Class Assignments and Standard Definitions Values are Available on the Web ..... A-2

---

# **1 General Information**

## Calibration Kit Overview

The Agilent 85036B and 85036E type-N calibration kits are used to calibrate Agilent network analyzers up to 3 GHz for measurements of components with 75 $\Omega$  type-N connectors.

### Kit Contents

#### The 85036B calibration kit contains the following:

- one male and one female 75 $\Omega$  type-N open termination
- one male and one female 75 $\Omega$  type-N short termination
- one male and one female 75 $\Omega$  type-N load
- three 75 $\Omega$  type-N to 75 $\Omega$  type-N adapters
- one female open center-conductor extender

Refer to [Table 6-1](#) and [Figure 6-1](#) for a complete list of kit contents and their associated part numbers.

#### The 85036E calibration kit contains the following:

- one male combination open/short termination
- one male 75 $\Omega$  type-N load

Refer to [Table 6-2](#) and [Figure 6-2](#) for a complete list of kit contents and their associated part numbers.

### Broadband Loads

The broadband loads are instrument-grade, 75 $\Omega$  terminations that have been optimized for performance up to 3 GHz. The rugged internal structure provides for highly repeatable connections. A distributed resistive element on sapphire provides excellent stability and return loss.

### Opens and Shorts

The opens and shorts are built from parts that are machined to the current state-of-the-art precision machining.

The short's inner conductors have a one-piece construction, common with the shorting plane. This construction provides for extremely repeatable connections.

The female open has a separate-piece inner conductor that is made from a low-dielectric-constant plastic to minimize compensation values.

Both the opens and shorts are constructed so that the pin depth can be controlled very tightly, thereby minimizing phase errors. Some of the opens and shorts have offsets. The lengths of these offsets are designed so that the difference in phase of their reflection coefficients is approximately 180 degrees at all frequencies.

## Adapters

Like the other devices in the kit, the adapters are built to very tight tolerances to provide good broadband performance. The adapters utilize a dual-beaded connector structure to ensure stable, repeatable connections. The beads are designed to minimize return loss and are separated far enough so that interaction between the beads is minimized.

The adapters are designed so that their nominal electrical lengths are the same, which allows them to be used in calibration procedures for non-insertable devices.

## Calibration Definitions

The calibration kit must be selected and the calibration definitions for the devices in the kit installed in the network analyzer prior to performing a calibration. Refer to your network analyzer user's guide for instructions on selecting the calibration kit and performing a calibration.

The calibration definitions can be:

- resident within the analyzer
- loaded from the provided disk
- entered from the front panel

Class assignments and standard definitions may change as more accurate model and calibration methods are developed. You can download the most recent class assignments and standard definitions from Agilent's Calibration Kit Definitions Web page at [www.na.tm.agilent.com/pna/caldefs/stddefs.html](http://www.na.tm.agilent.com/pna/caldefs/stddefs.html).

## Installation of the Calibration Definitions

The calibration definitions for the kit may be permanently installed in the internal memory or hard disk of the network analyzer.

If the calibration definitions for the kit are not permanently installed in the network analyzer, they must be manually entered. Refer to your network analyzer user's guide for instructions.

## Equipment Required but Not Supplied

Gages, torque and open-end wrenches, ESD protective devices, and various connector cleaning supplies are *not* included in the calibration kit but are required to ensure successful operation of the calibration kit. Refer to [Table 6-3 on page 6-5](#) for ordering information.

## Incoming Inspection

Verify that the shipment is complete by referring to [Figure 1-1 on page 1-5](#).

Check for damage. The foam-lined storage case provides protection during shipping.

If the case or any device appears damaged, or if the shipment is incomplete, contact Agilent. See [“Contacting Agilent” on page 5-4](#). Agilent will arrange for repair or replacement of incomplete or damaged shipments without waiting for a settlement from the transportation company.

When you send the kit or device to Agilent, include a service tag (found near the end of this manual) with the following information:

- your company name and address
- the name of a technical contact person within your company, and the person's complete phone number
- the model number and serial number of the kit
- the part number and serial number of the device
- the type of service required
- a *detailed* description of the problem



**Figure 1-1 Calibration Kit Contents**

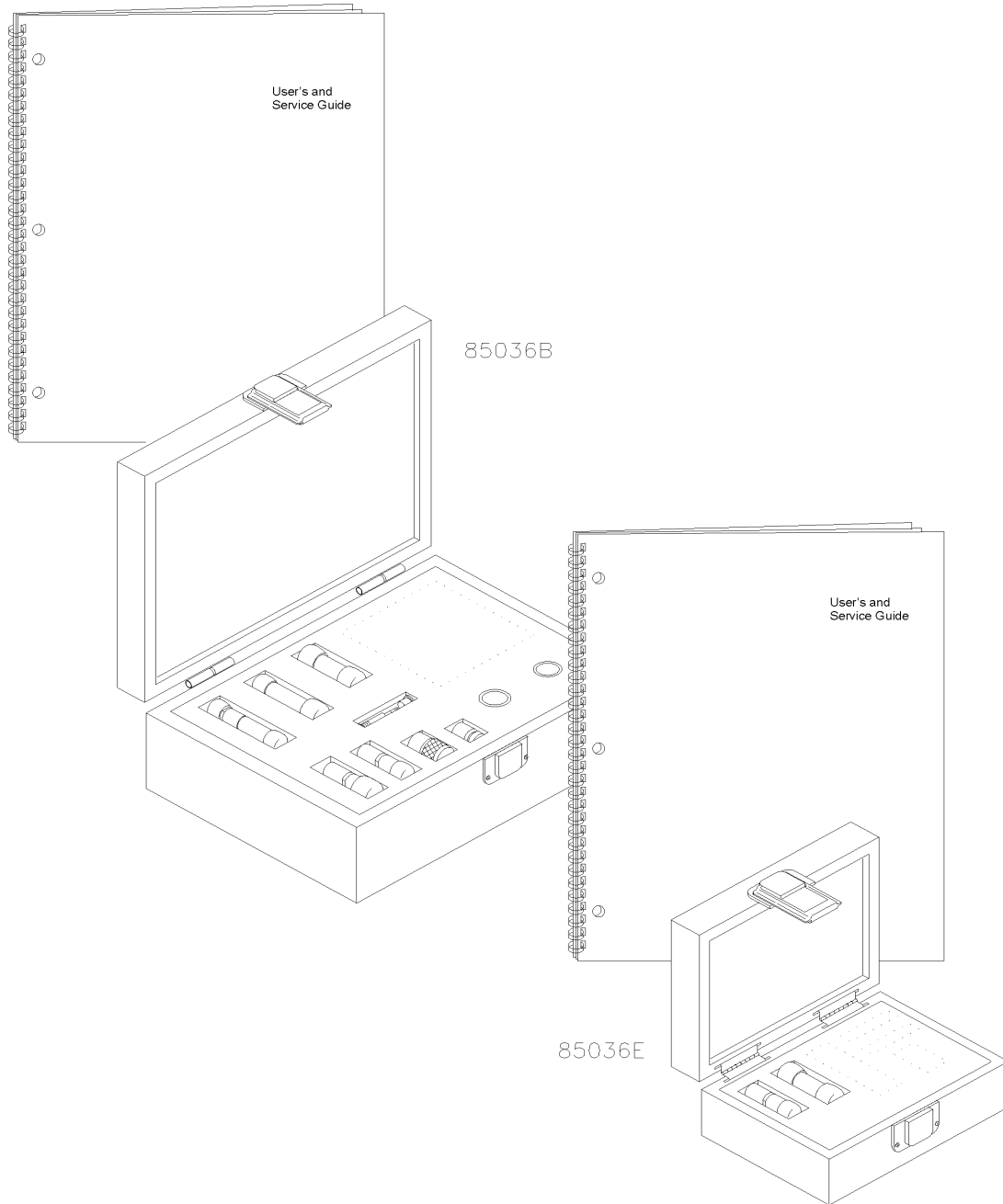

hj71be

---

## Recording the Device Serial Numbers

In addition to the kit serial number, the devices in this kit are individually serialized (serial numbers are labeled onto the body of each device). Record these serial numbers in [Table 1-1](#) for the 85036B and [Table 1-2](#) for the 85036E. Recording the serial numbers will prevent confusing the devices in this kit with similar devices in other kits.

**Table 1-1 Serial Number Record for 85036B**

Device	Serial Number
<b>Calibration kit</b>	_____
Male broadband load	_____
Female broadband load	_____
Male open	_____
Female open body	_____
Male short	_____
Female short	_____
Type-N male to male adapter	_____
Type-N- female to female adapter	_____
Type-N- male to female adapter	_____
Female open center-conductor extender	_____

**Table 1-2 Serial Number Record for 85036E**

Device	Serial Number
<b>Calibration kit</b>	_____
Male broadband load	_____
Male combination open/short	_____

## Calibration Kits Documented in this Manual

This manual applies to any 85036B or 85036E calibration kit whose serial prefix is listed on the title page. If your calibration kit has a different serial number prefix than the one listed on the title page, refer to [“Calibration Kit History”](#) below for information on how this manual applies.

### Calibration Kit History

This section describes calibration kits with serial number prefixes different than those listed on the title page.

#### Agilent 85036B kits with serial prefix 3102A and below

- 75 ohm load specification: return loss  $\geq$  45 db, dc to 2 GHz
- all other kit components unspecified

85036B calibration kits with serial number prefix 3102A and below should meet the specifications published in this manual. If you wish to have your kit recertified to current specifications, contact your nearest Agilent service center. For contact information, see [“Contacting Agilent”](#) on page 5-4.

#### Agilent 85036B kits with serial prefix 3103A and below

These calibration kits had a center conductor extender with a smaller body. Therefore, a different procedure was used for connecting the female open. If you're using one of the smaller extenders, replace the steps in [“Connecting and Disconnecting the Two-Piece Female Open \(85036B\)”](#) on page 3-9 of this manual with the steps below.

1. Mate the center conductor extender to the male pin of the test port.
2. Connect the open body to the test port by carefully guiding it over the extender.
3. To disconnect the open, carefully remove the open body first.

The part numbers in this manual are the recommended replacement parts for these kits (*including the center conductor extender*).

## Clarifying the Terminology of a Connector Interface

In this document and in the prompts of the PNA calibration wizard, the gender of cable connectors and adapters is referred to in terms of the center conductor. For example, a connector or device designated as 1.85 mm –f– has a 1.85 mm female center conductor.

**8510-series, 872x, and 875x ONLY:** In contrast, during a measurement calibration, the network analyzer softkey menus label a 1.85 mm calibration device with reference to the sex of the analyzer’s test port connector—not the calibration device connector. For example, the label SHORT (F) refers to the short that is to be connected to the female test port. This will be a male short from the calibration kit.

**Table 1-3 Clarifying the Sex of Connectors: Examples**

Terminology	Meaning
Short –f–	Female short (female center conductor)
Short (f)	Male short (male center conductor) to be connected to female port

A connector gage is referred to in terms of the connector that it measures. For instance, a male connector gage has a female connector on the gage so that it can measure male devices.

---

## Preventive Maintenance

The best techniques for maintaining the integrity of the devices in this kit include:

- routine visual inspection
- cleaning
- proper gaging
- proper connection techniques

All of the above are described in [Chapter 3](#), “Use, Maintenance, and Care of the Devices.” Failure to detect and remove dirt or metallic particles on a mating plane surface can degrade repeatability and accuracy and can damage any connector mated to it. Improper connections, resulting from pin depth values being out of the limits (see [Table 2-3 on page 2-3](#)), or from bad connections, can also damage these devices.

---

## **2 Specifications**

---

## Environmental Requirements

---

**NOTE** Samples of this product have been type-tested in accordance with the Agilent Environmental Test Manual and verified to be robust against the environmental stresses of storage, transportation and end-use; those stresses include but are not limited to temperature, humidity, shock, vibration, altitude and power-line conditions. Test methods are aligned with IEC 60068-2 and levels are similar to MIL-PRF-28800F Class 3.

---

**Table 2-1 Environmental Requirements**

Parameter	Limits
Operating temperature <sup>a</sup>	+15 °C to +35 °C (+59 °F to +95 °F)
Error-corrected temperature range <sup>b</sup>	±1 °C of measurement calibration temperature
Storage temperature	-40 °C to +75 °C (-40 °F to +167 °F)
Altitude	
Operation	< 4,500 meters (≈15,000 feet)
Storage	< 4,500 meters (≈15,000 feet)
Relative humidity	Type tested, 0% to 95% at 40 °C, non-condensing

- a. The temperature range over which the calibration standards maintain conformance to their specifications.
- b. The allowable network analyzer ambient temperature drift during measurement calibration and during measurements when the network analyzer error correction is turned on. Also, the range over which the network analyzer maintains its specified performance while correction is turned on.

### Temperature—What to Watch Out For

Changes in temperature can affect electrical characteristics. Therefore, the operating temperature is a critical factor in performance. During a measurement calibration, the temperature of the calibration devices must be stable and within the range specified in [Table 2-1](#).

---

**IMPORTANT** Avoid unnecessary handling of the devices during calibration because your fingers are a heat source.

---

## Mechanical Specifications

The mechanical specifications in [Table 2-2](#) apply to the devices in the 85036B and the 85036E 75  $\Omega$  type-N calibration kits.

**Table 2-2 Mechanical Specifications**

Device	Specification
Type-N Male Open	Inside diameter of outer conductor: 6.985 to 7.010
Type-N Male Short	Inside diameter of outer conductor: $7 \pm 0.015$ mm Distance from reference plane to shorting plane: $5.29 \pm 0.013$ mm

## Supplemental Mechanical Characteristics

Supplemental characteristics are values which are typically met by a majority of the calibration kit devices tested at Agilent. These supplemental characteristics are intended to provide information useful in calibration kit applications by giving typical, but non-warranted performance parameters. [Table 2-3](#) lists the typical characteristics of the devices in this kit.

**Table 2-3 Mechanical Characteristics**

Device	Characteristic
Type-N Male Short	Diameter of male pin: $0.897 \pm 0.013$ mm
All Type-N Male Connectors	Pin depth: 0.207 to 0.210 inch
All Type-N Female Connectors	Pin depth: 0.204 to 0.207 inch

## Electrical Specifications

The electrical specifications in [Table 2-4](#) apply to the devices in your calibration kit when connected with an Agilent precision interface.

**Table 2-4 Electrical Specifications**

Device	Specification	Frequency (GHz)
Loads <sup>a</sup>	Return loss $\geq 46$ dB ( $\rho \leq 0.00501$ )	DC to $\leq 2$
	Return loss $\geq 40$ dB ( $\rho \leq 0.01000$ )	$> 2$ to $\leq 3$

a. 23° +5 °C; typical resistance change:  $\pm 300$  ppm/°C

## Certification

Agilent Technologies certifies that this product met its published specifications at the time of shipment from the factory. Agilent further certifies that its calibration measurements are traceable to the United States National Institute of Standards and Technology (NIST) to the extent allowed by the institute's calibration facility, and to the calibration facilities of other International Standards Organization members. See [“How Agilent Verifies the Devices in This Kit” on page 4-2](#) for more information.



---

## **3 Use, Maintenance, and Care of the Devices**

## Electrostatic Discharge

Protection against ESD (electrostatic discharge) is essential while connecting, inspecting, or cleaning connectors attached to a static-sensitive circuit (such as those found in test sets).

Static electricity can build up on your body and can easily damage sensitive internal circuit elements when discharged. Static discharges too small to be felt can cause permanent damage. Devices such as calibration components and devices under test (DUTs), can also carry an electrostatic charge. To prevent damage to the test set, components, and devices:

- *always* wear a grounded wrist strap having a 1 M $\Omega$  resistor in series with it when handling components and devices or when making connections to the test set.
- *always* use a grounded, conductive table mat while making connections.
- *always* wear a heel strap when working in an area with a conductive floor. If you are uncertain about the conductivity of your floor, wear a heel strap.
- *always* ground yourself before you clean, inspect, or make a connection to a static-sensitive device or test port. You can, for example, grasp the grounded outer shell of the test port or cable connector briefly.
- *always* ground the center conductor of a test cable before making a connection to the analyzer test port or other static-sensitive device. This can be done as follows:
  1. Connect a short (from your calibration kit) to one end of the cable to short the center conductor to the outer conductor.
  2. While wearing a grounded wrist strap, grasp the outer shell of the cable connector.
  3. Connect the other end of the cable to the test port.
  4. Remove the short from the cable.

Refer to [Chapter 6](#) , “[Replaceable Parts](#),” for part numbers and instructions for ordering ESD protective devices.

**Figure 3-1 ESD Protection Setup**

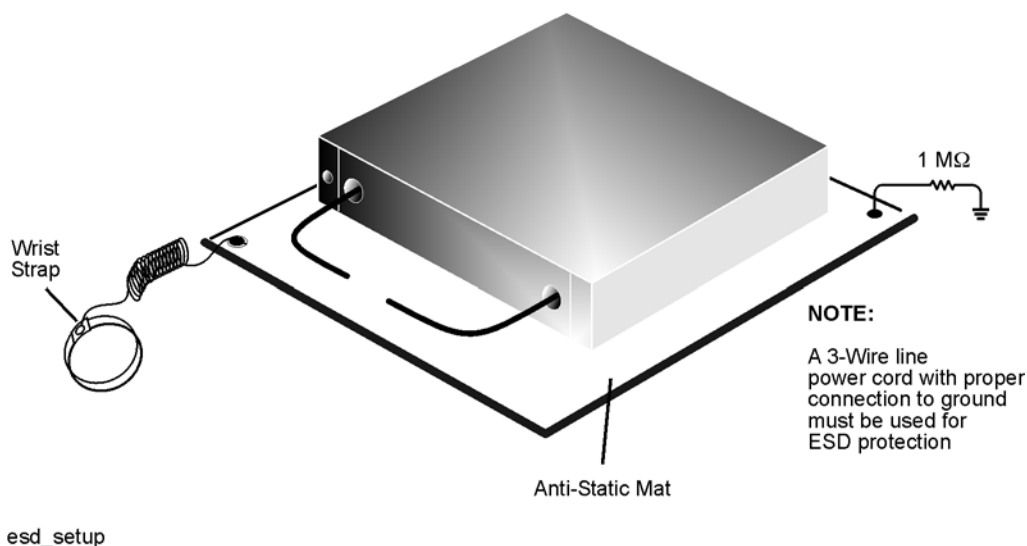

## Visual Inspection

Visual inspection and, if necessary, cleaning should be done every time a connection is made. Metal particles from the connector threads may fall into the connector when it is disconnected. One connection made with a dirty or damaged connector can damage both connectors beyond repair.

In some cases, magnification is necessary to see damage on a connector; a magnifying device with a magnification of  $\geq 10\times$  is recommended. However, not all defects that are visible only under magnification will affect the electrical performance of the connector. Use the following guidelines when evaluating the integrity of a connector.

### Look for Obvious Defects and Damage First

Examine the connectors first for obvious defects and damage: badly worn plating on the connector interface, deformed threads, or bent, broken, or misaligned center conductors. Connector nuts should move smoothly and be free of burrs, loose metal particles, and rough spots.

### What Causes Connector Wear?

Connector wear is caused by connecting and disconnecting the devices. The more use a connector gets, the faster it wears and degrades. The wear is greatly accelerated when connectors are not kept clean, or are connected incorrectly.

Connector wear eventually degrades performance of the device. Calibration devices should have a long life if their use is on the order of a few times per week. Replace devices with worn connectors.

The test port connectors on the network analyzer test set may have many connections each day, and are therefore more subject to wear. It is recommended that an adapter be used as a test port saver to minimize the wear on the test set's test port connectors.

### Inspect the Mating Plane Surfaces

Flat contact between the connectors at all points on their mating plane surfaces is required for a good connection. Look especially for deep scratches or dents, and for dirt and metal particles on the connector mating plane surfaces. Also look for signs of damage due to excessive or uneven wear or misalignment.

Light burnishing of the mating plane surfaces is normal, and is evident as light scratches or shallow circular marks distributed more or less uniformly over the mating plane surface. Other small defects and cosmetic imperfections are also normal. None of these affect electrical or mechanical performance.

If a connector shows deep scratches or dents, particles clinging to the mating plane surfaces, or uneven wear, clean and inspect it again. Devices with damaged connectors should be discarded. Determine the cause of damage before connecting a new, undamaged connector in the same configuration.

## Cleaning Connectors

Clean connectors are essential for ensuring the integrity of RF and microwave coaxial connections.

### 1. Use Compressed Air or Nitrogen

---

**WARNING** Always use protective eyewear when using compressed air or nitrogen.

---

Use compressed air (or nitrogen) to loosen particles on the connector mating plane surfaces.

You can use any source of clean, dry, low-pressure compressed air or nitrogen that has an effective oil-vapor filter and liquid condensation trap placed just before the outlet hose.

Ground the hose nozzle to prevent electrostatic discharge, and set the air pressure to less than 414 kPa (60 psi) to control the velocity of the air stream. High-velocity streams of compressed air can cause electrostatic effects when directed into a connector. These electrostatic effects can damage the device. Refer to “[Electrostatic Discharge](#)” earlier in this chapter for additional information.

### 2. Clean the Connector Threads

---

**WARNING** Keep isopropyl alcohol away from heat, sparks, and flame. Store in a tightly closed container. It is extremely flammable. In case of fire, use alcohol foam, dry chemical, or carbon dioxide; water may be ineffective.

**Use isopropyl alcohol with adequate ventilation and avoid contact with eyes, skin, and clothing. It causes skin irritation, may cause eye damage, and is harmful if swallowed or inhaled. It may be harmful if absorbed through the skin. Wash thoroughly after handling.**

**In case of spill, soak up with sand or earth. Flush spill area with water.**

**Dispose of isopropyl alcohol in accordance with all applicable federal, state, and local environmental regulations.**

---

Use a lint-free swab or cleaning cloth moistened with isopropyl alcohol to remove any dirt or stubborn contaminants on a connector that cannot be removed with compressed air or nitrogen. Refer to [Table 6-3 on page 6-5](#) for a part number for cleaning swabs.

- a. Apply a small amount of isopropyl alcohol to a lint-free cleaning swab.
- b. Clean the connector threads.
- c. Let the alcohol evaporate, then blow the threads dry with a gentle stream of clean, low-pressure compressed air or nitrogen. Always completely dry a connector before

you reassemble or use it.

### 3. Clean the Mating Plane Surfaces

- a. Apply a small amount of isopropyl alcohol to a lint-free cleaning swab.
- b. Clean the center and outer conductor mating plane surfaces. When cleaning a female connector, avoid snagging the swab on the center conductor contact fingers by using short strokes.
- c. Let the alcohol evaporate, then blow the connector dry with a gentle stream of clean, low-pressure compressed air or nitrogen. Always completely dry a connector before you reassemble or use it.

### 4. Inspect

Inspect the connector to make sure that no particles or residue remain. Refer to [“Visual Inspection” on page 3-3](#).

## Connections

Good connections require a skilled operator. *The most common cause of measurement error is bad connections.* The following procedures illustrate how to make good connections.

---

**CAUTION** Never mate a 50 ohm connector with a 75 ohm connector. The larger center pin of a male 50 ohm connector will destroy the contact fingers of a female 75 ohm connector.

---

### How to Make a Connection

#### Preliminary Connection

1. Ground yourself and all devices. Wear a grounded wrist strap and work on a grounded, conductive table mat. Refer to [“Electrostatic Discharge” on page 3-2](#) for ESD precautions.
2. Visually inspect the connectors. Refer to [“Visual Inspection” on page 3-3](#).
3. If necessary, clean the connectors. Refer to [“Cleaning Connectors” on page 3-4](#).
4. Carefully align the connectors. The male connector center pin must slip concentrically into the contact finger of the female connector.
5. Push the connectors straight together.

---

**CAUTION** Do *not* turn the device body. Only turn the connector nut. Damage to the center conductor can occur if the device body is twisted.

---

Do *not* twist or screw the connectors together. As the center conductors mate, there is usually a slight resistance.

6. The preliminary connection is tight enough when the mating plane surfaces make uniform, light contact. Do not overtighten this connection.

A connection in which the outer conductors make gentle contact at all points on both mating surfaces is sufficient. Very light finger pressure is enough to accomplish this.

7. Make sure the connectors are properly supported. Relieve any side pressure on the connection from long or heavy devices or cables.

#### Final Connection Using a Torque Wrench

1. Use a torque wrench to make a final connection. [Table 3-1](#) provides information about the torque wrench recommended for use with this calibration kit. A torque wrench is *not* included in the calibration kit. Refer to [Chapter 6](#) for part number and ordering information.

**Table 3-1 Torque Wrench Information**

Connector Type	Torque Setting	Torque Tolerance
Type-N	135 N-cm (12 in-lb)	$\pm 13.5$ N-cm ( $\pm 1.2$ in-lb)

Using a torque wrench guarantees that the connection is not too tight, preventing possible connector damage. It also guarantees that all connections are equally tight each time.

- Prevent the rotation of anything other than the connector nut that you are tightening. It may be possible to do this by hand if one of the connectors is fixed (as on a test port). In all situations, however, it is recommended that you use an open-end wrench to keep the body of the device from turning. Refer to [Chapter 6 “Replaceable Parts”](#) for part number and ordering information.
- Position both wrenches within 90 degrees of each other before applying force. See [Figure 3-2](#). Wrenches opposing each other (greater than 90 degrees apart) will cause a lifting action which can misalign and stress the connections of the devices involved. This is especially true when several devices are connected together.

**Figure 3-2 Wrench Positions**

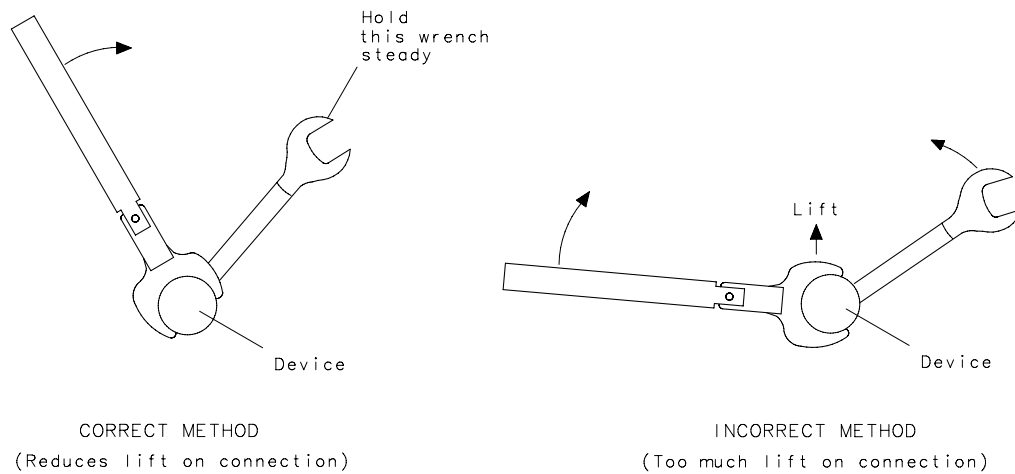

wj56f

4. Hold the torque wrench lightly, at the end of the handle only (beyond the groove). See [Figure 3-3](#).

**Figure 3-3 Using the Torque Wrench**

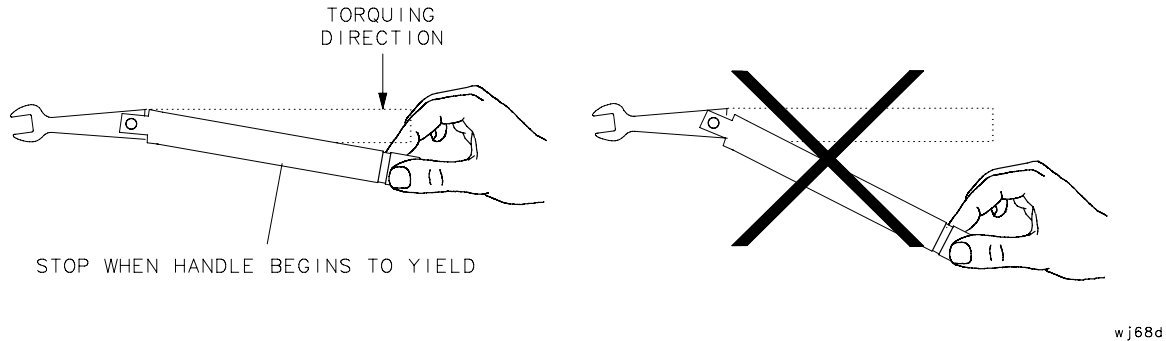

5. Apply downward force perpendicular to the wrench handle. See [Figure 3-3](#). This applies torque to the connection through the wrench.  
Do not hold the wrench so tightly that you push the handle straight down along its length rather than pivoting it, otherwise you apply an unknown amount of torque.
6. Tighten the connection just to the torque wrench break point. The wrench handle gives way at its internal pivot point. See [Figure 3-3](#). Do not tighten the connection further.

---

**CAUTION** You don't have to fully break the handle of the torque wrench to reach the specified torque; doing so can cause the handle to kick back and loosen the connection. Any give at all in the handle is sufficient torque.

---

Do not pivot the wrench handle on your thumb or other fingers, otherwise you apply an unknown amount of torque to the connection when the wrench reaches its break point.

Do not twist the head of the wrench relative to the outer conductor mating plane. If you do, you apply more than the recommended torque.



### Connecting and Disconnecting the Two-Piece Female Open (85036B)

The female open standard in the 85036B calibration kit is composed of two parts: the open body (outer conductor) and the center conductor extender. Refer to [Figure 3-4](#).

**Figure 3-4 Connecting the Two-Piece Female Open**

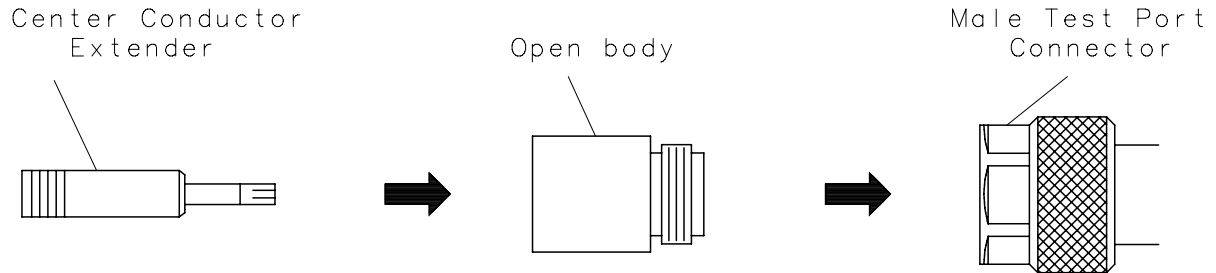

To connect the female open:

1. Connect the open body to the male test port.
2. Insert the center conductor extender into the hole at the end of the body and push gently until the center conductors mate.

To disconnect the female open:

1. Remove the center conductor extender by pulling gently outwards without twisting, rocking, or bending the extender or the body.
2. Disconnect the body from the test port.

### How to Separate a Connection

To avoid lateral (bending) force on the connector mating plane surfaces, always support the devices and connections.

---

**CAUTION** Turn the connector nut, *not* the device body. Major damage to the center conductor can occur if the device body is twisted.

---

1. Use an open-end wrench to prevent the device body from turning.
2. Use another open-end wrench to loosen the connector nut.
3. Complete the separation by hand, turning only the connector nut.
4. Pull the connectors straight apart without twisting, rocking, or bending either of the connectors.

## **Handling and Storage**

- Install the protective end caps and store the calibration devices in the foam-lined storage case when not in use.
- Never store connectors loose in a box, desk, or bench drawer. This is the most common cause of connector damage during storage.
- Keep connectors clean.
- Do not touch mating plane surfaces. Natural skin oils and microscopic particles of dirt are easily transferred to a connector interface and are very difficult to remove.
- Do not set connectors contact-end down on a hard surface. The plating and the mating plane surfaces can be damaged if the interface comes in contact with any hard surface.

---

## **4 Performance Verification**

## Introduction

The performance of your calibration kit can only be verified by returning the kit to Agilent Technologies for recertification. The equipment required to verify the specifications of the devices in the kit has been specially manufactured and is not commercially available.

---

## How Agilent Verifies the Devices in This Kit

Agilent verifies the specifications of these devices as follows:

1. The residual microwave error terms of the test system are verified with precision airlines and shorts that are directly traced to NIST (National Institute of Standards and Technology). The airline and short characteristics are developed from mechanical measurements. The mechanical measurements and material properties are carefully modeled to give very accurate electrical representation. The mechanical measurements are then traced to NIST through various plug and ring gages and other mechanical measurements.
2. Each calibration device is electrically tested on this system. For the initial (before sale) testing of the calibration devices, Agilent includes the test measurement uncertainty as a guardband to guarantee each device meets the published specification. For recertifications (after sale), no guardband is used and the measured data is compared directly with the specification to determine the pass or fail status. The measurement uncertainty for each device is, however, recorded in the calibration report that accompanies recertified kits.

These two steps establish a traceable link to NIST for Agilent to the extent allowed by the institute's calibration facility. The specifications data provided for the devices in this kit is traceable to NIST through Agilent Technologies.

---

## Recertification

The following will be provided with a recertified kit:

- a new calibration sticker affixed to the case
- a certificate of calibration
- a calibration report for each device in the kit listing measured values, specifications, and uncertainties

---

**NOTE** A list of NIST traceable numbers may be purchased upon request to be included in the calibration report.

---

Agilent Technologies offers a *Standard* calibration for the recertification of this kit. For more information, contact Agilent Technologies. See “Contacting Agilent” on page 4.

### How Often to Recertify

The suggested initial interval for recertification is 12 months or sooner. The actual need for recertification depends on the use of the kit. After reviewing the results of the initial recertification, you may establish a different recertification interval that reflects the usage and wear of the kit.

---

**NOTE** The recertification interval should begin on the date the kit is *first used* after the recertification date.

---

---

## Where to Send a Kit for Recertification

Contact Agilent Technologies for information on where to send your kit for recertification. See “Contacting Agilent” on page 4.

When you return the kit, complete and attach a service tag. Refer to [“Returning a Kit or Device to Agilent” on page 5-3](#) for details.



---

## **5 Troubleshooting**

## Troubleshooting Process

If you suspect a bad calibration, or if your network analyzer does not pass performance verification, follow the steps in [Figure 5-1](#).

**Figure 5-1 Troubleshooting Flowchart**

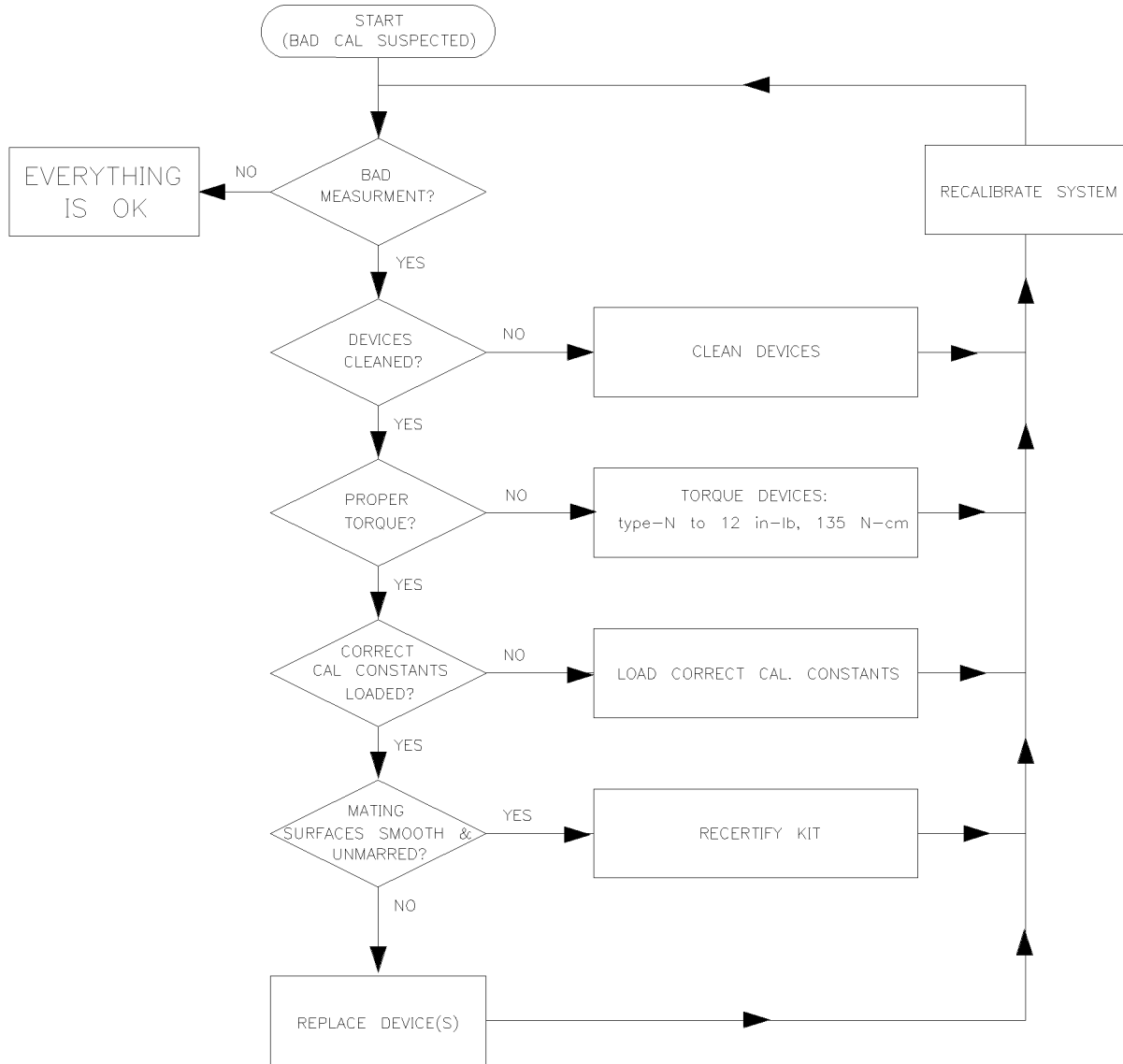

h j75be



## Where to Look for More Information

This manual contains limited information about network analyzer system operation. For detailed information on using a VNA, ENA or PNA series network analyzer, refer to the appropriate user guide or online Help.

- To view the ENA or PNA online Help, press the Help key on the front panel of the network analyzer.
- To view an online VNA user guide, use the following steps:
  1. Go to *www.agilent.com*.
  2. Enter your VNA model number (Ex: 8753ES) in the Search box and click **Search**.
  3. Under the heading **Manuals & Guides**, click on the title/hyperlink for the document PDF you want to view.

If you need additional information, see “Contacting Agilent” on page 4.

---

## Returning a Kit or Device to Agilent

If your kit or device requires service, contact the Agilent Technologies office nearest you for information on where to send it. See “Contacting Agilent” below. Include a service tag (located near the end of this manual) on which you provide the following information:

- your company name and address
- a technical contact person within your company, and the person's complete phone number
- the model number and serial number of the kit
- the part number and serial number of each device
- the type of service required
- a *detailed* description of the problem and how the device was being used when the problem occurred (such as calibration or measurement)

## Contacting Agilent

Assistance with test and measurements needs and information on finding a local Agilent office are available on the Web at:

*[www.agilent.com/find/assist](http://www.agilent.com/find/assist)*

If you do not have access to the Internet, please contact your Agilent field engineer.

---

**NOTE** In any correspondence or telephone conversation, refer to the Agilent product by its model number and full serial number. With this information, the Agilent representative can determine whether your product is still within its warranty period.

---

---

## **6 Replaceable Parts**

## Introduction

Table 6-1 lists the replacement part numbers for items included in the 85036B calibration kit and Figure 6-1 illustrates each of these items.

Table 6-2 lists the replacement part numbers for items included in the 85036E calibration kit and Figure 6-2 illustrates each of these items.

Table 6-3 lists the replacement part numbers for items recommended or required for successful operation but not included in the calibration kit.

To order a listed part, note the description, part number, and quantity desired. Telephone or send your order to Agilent Technologies. See “Contacting Agilent” on page 5-4.

**Table 6-1 Replaceable Parts for the 85036B Calibration Kit**

Description	Qty Per Kit	Agilent Part Number
<b>Calibration Devices (75Ω Type-N)<sup>a</sup></b>		
Male broadband load	1	00909-60019
Female broadband load	1	00909-60020
Male short	1	85036-60012
Female short	1	85036-60011
Male open	1	85032-60007
Female open body	1	85032-20001
Female open center conductor extender	1	85036-60010
<b>Adapters</b>		
Type-N-male to male	1	85036-60013
Type-N-female to female	1	85036-60014
Type-N-male to female	1	85036-60015
<b>Calibration Kit Storage Case</b>		
Box	1	85036-80001
Foam pad set	1	85036-80002
<b>Miscellaneous Items</b>		
User’s and service guide <sup>b</sup>	1	85036-90016
Male protective end caps	as required	1401-0214
Female protective end caps	as required	1401-0225
Tube package (for center conductor extender)	1	1540-1027

a. Refer to “Clarifying the Terminology of a Connector Interface” on page 1-8.

b. See “Printing Copies of On-Line Documentation” on page -ii.

**Figure 6-1 Replaceable Parts for the 85036B Calibration Kit**

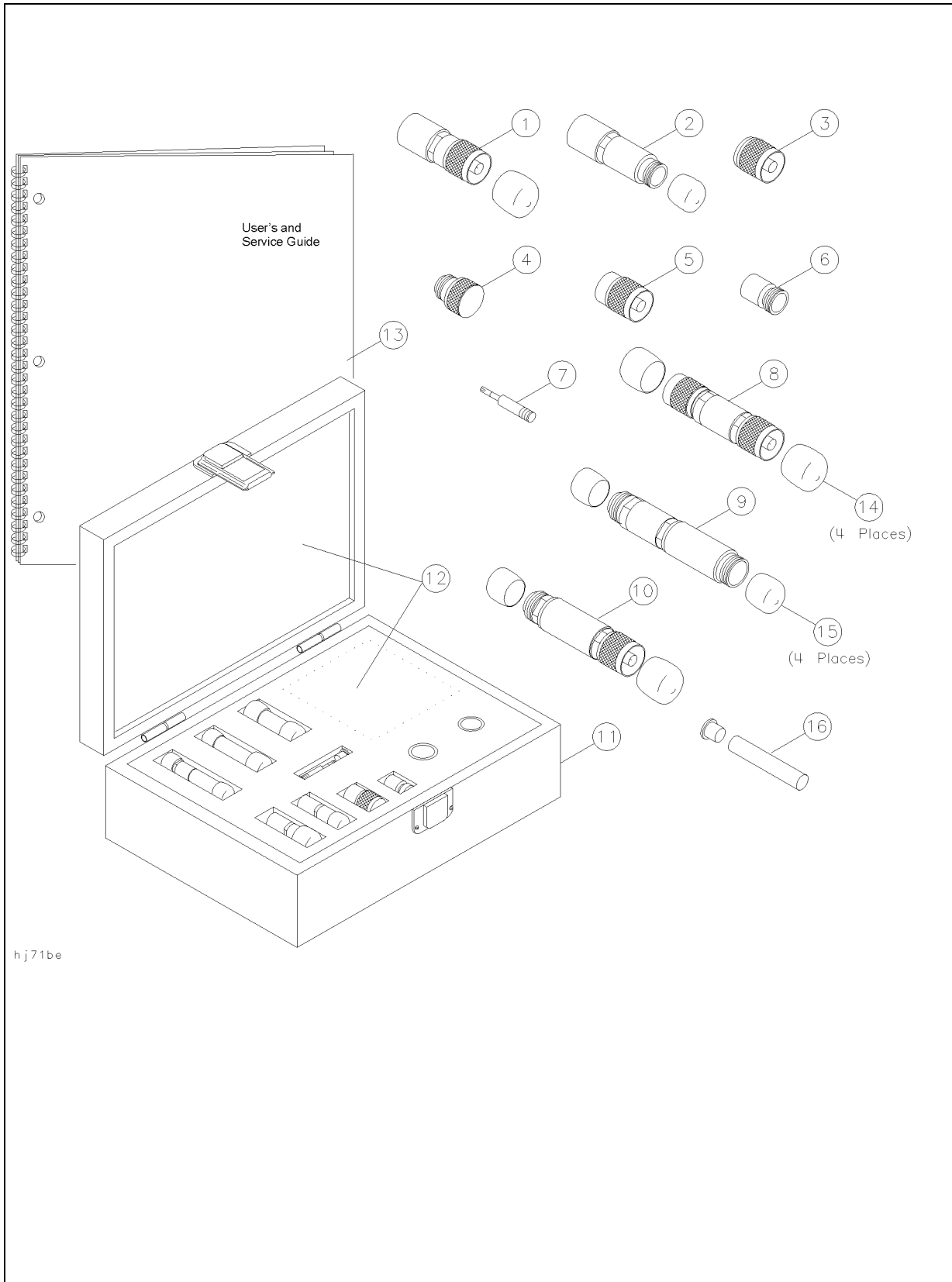
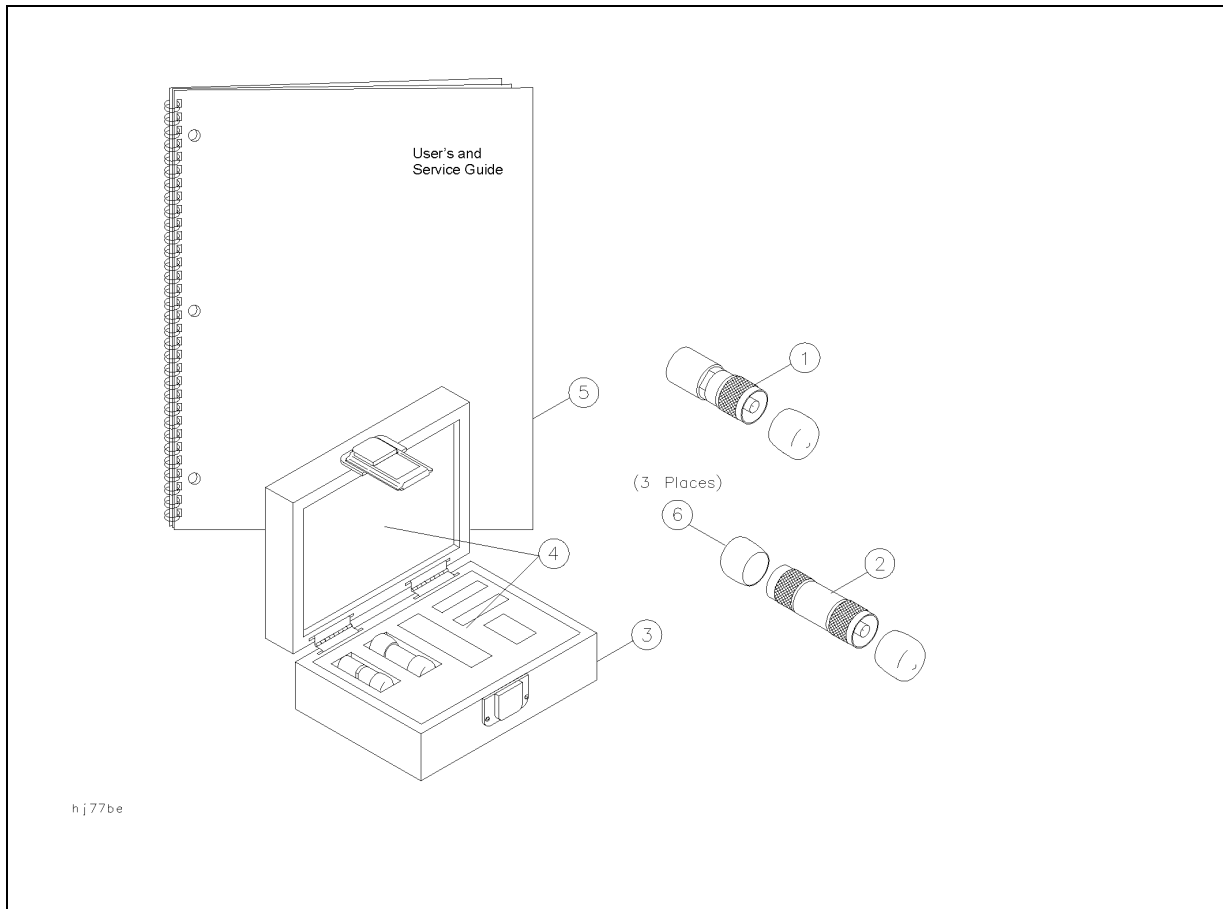

**Table 6-2 Replaceable Parts for the 85036E Calibration Kit**

Description	Qty Per Kit	Agilent Part Number
<b>Calibration Devices (75Ω Type-N)</b>		
Male broadband load	1	00909-60019
Male combination open/short	1	85036-60016
<b>Calibration Kit Storage Case</b>		
Box	1	9211-1582
Foam pad set	1	85023-80005
<b>Miscellaneous Items</b>		
User's and service guide <sup>a</sup>	1	85036-90016
Male protective end cap	as required	1401-0214

a. See "Printing Copies of On-Line Documentation" on page -ii.

**Figure 6-2 Replaceable Parts for the 85036E Calibration Kit**



**Table 6-3 Replaceable Parts—Items Not Included in the 85036B and 85036E Calibration Kits**

Description	Qty	Agilent Part Number
<b>Connector Gages (75Ω Type-N)</b>		
Connector gage set	1	85036B K01
<b>Wrenches</b>		
3/4 in, 135 N-cm (12 in-lb) torque wrench	1	8710-1766
1/2 in and 9/16 in open-end wrench	1	8710-1770
3/4 in open-end wrench	1	8720-0011
<b>ESD Protective Devices</b>		
Grounding wrist strap	1	9300-1367
5 ft grounding cord for wrist strap	1	9300-0980
2 ft by 4 ft conductive table mat with 15 ft grounding wire	1	9300-0797
ESD heel strap	1	9300-1308
<b>Connector Cleaning Supplies</b>		
Anhydrous isopropyl alcohol (>92% pure) <sup>a</sup>	30 ml	--
Foam tipped cleaning swabs	100	9301-1243
<b>Miscellaneous Items</b>		
Connector care - quick reference card	1	08510-90360

a. Agilent can no longer safely ship isopropyl alcohol, so customers should purchase it locally.





---

# **A Standard Definitions**

## **Class Assignments and Standard Definitions Values are Available on the Web**

Class assignments and standard definitions may change as more accurate model and calibration methods are developed. You can download the most recent class assignments and standard definitions from Agilent's Calibration Kit Definitions Web page at <http://na.tm.agilent.com/pna/caldefs/stddefs.html>.

For a detailed discussion of calibration kits, refer to the Agilent Application Note, "Specifying Calibration Standards and Kits for Agilent Vector Network Analyzers." This application note covers calibration standard definitions, calibration kit content and its structure requirements for Agilent vector network analyzers. It also provides some examples of how to set up a new calibration kit and how to modify an existing calibration kit definition file. To download a free copy, go to [www.agilent.com](http://www.agilent.com) and enter literature number 5989-4840EN in the Search window.

**A**

adapters, [1-3](#)  
 part numbers, [6-5](#)  
 Agilent  
 application note, [A-2](#)  
 offices, [5-3](#)  
 alcohol  
 isopropyl  
 as cleaning solvent, [3-4](#)  
 altitude, [2-2](#)

**B**

broadband loads, [1-2](#)

**C**

cal kit  
 contents, [1-2](#)  
 overview, [1-2](#)  
 return to Agilent, [5-3](#)  
 serial number, [1-6](#)  
 calibration  
 bad, [5-2](#)  
 certificate of, [4-2](#)  
 constants  
 permanently stored, [1-3](#)  
 constants, *See* calibration definitions  
 definitions  
 entering, [1-3](#)  
 permanently stored, [1-3](#)  
 label, [4-3](#)  
 label part number, [6-5](#)  
 report, [4-2](#)  
 standards, [2-4](#)  
 temperature, [2-2](#)  
 calibration kit  
 Agilent Application Note, [A-2](#)  
 contents, [1-2](#)  
 history, [1-7](#)  
 modifying definition files, [A-2](#)  
 overview, [1-2](#)  
 return to Agilent, [5-3](#)  
 serial number, [1-6](#)  
 certificate of calibration, [4-2](#)  
 certification  
 specifications, [2-4](#)  
 class assignments  
 downloading from Agilent Web site, [A-2](#)  
 cleaning connectors, [3-4](#)  
 cleaning supplies, [1-3](#)  
 ordering, [6-5](#)  
 part numbers, [6-5](#)  
 compressed air or nitrogen, [3-4](#)  
 connections, [3-2](#), [3-6](#), [3-9](#)  
 cautions in making, [3-6](#)  
 disconnecting, [3-9](#)  
 ESD concerns, [3-6](#)  
 final, [3-6](#)  
 how to make, [3-6](#)  
 preliminary, [3-6](#)

two-piece female open, [3-9](#)  
 undoing, [3-9](#)  
 using a torque wrench, [3-6](#)  
 connector  
 cleaning, [3-4](#)  
 cleaning supplies, [6-5](#)  
 damage, [3-3](#)  
 life, [3-3](#)  
 mating plane, [3-5](#)  
 sex, [1-8](#)  
 threads, [3-4](#)  
 visual inspection, [3-3](#)  
 wear, [3-3](#)  
 constants, calibration, *See* calibration definitions  
 contacting Agilent Technologies, [5-3](#)  
 contents  
 kit, [1-2](#)  
**D**  
 damage  
 shipment, [1-4](#)  
 to connectors, [3-3](#)  
 data, recertification, [4-2](#)  
 defective connectors, [3-3](#)  
 definitions  
 calibration, [1-3](#)  
 device  
 connecting, [3-6](#)  
 disconnecting, [3-9](#)  
 handling, [3-10](#)  
 how Agilent verifies, [4-2](#)  
 maintenance, [1-8](#)  
 part numbers, [6-5](#)  
 return to Agilent, [5-3](#)  
 serial numbers, [1-6](#)  
 storage, [3-10](#)  
 temperature, [2-2](#)  
 visual inspection, [3-3](#)  
 disconnecting the two-piece female open, [3-9](#)  
 disconnections, [3-9](#)  
 distance from ref plane to shorting plane,  
 specifications, [2-3](#)  
 documentation  
 warranty, [-ii](#)  
 downloading class assignments & std definitions  
 from the Web, [A-2](#)

**E**

electrical specifications, [2-4](#)  
 electrostatic discharge, [3-2](#)  
 supplies  
 part numbers, [6-5](#)  
 when making connections, [3-6](#)  
 environmental requirements, [2-2](#)  
 equipment  
 required, [1-3](#)  
 but not supplied, [1-3](#), [6-2](#), [6-5](#)  
 supplied, [1-2](#), [6-2](#), [6-4](#)  
 ESD, [3-2](#)  
 precautions, [3-2](#), [3-4](#)

---

# Index

supplies  
part numbers, 6-5  
when making connections, 3-6

## F

female open, 3-9  
connecting, 3-9  
disconnecting, 3-9  
frequency  
range, 2-4  
specifications, 2-4

## G

gage  
connector  
master, 6-5  
gage master  
part numbers, 6-5  
gender, connector, 1-8

## H

handling, 3-10  
history, calibration kit, 1-7  
humidity, 2-2

## I

incoming inspection, 1-4  
information, troubleshooting, 5-3  
inside diameter of outer conductor, specifications, 2-3  
inspection  
damage, 3-3  
defects, 3-3  
incoming, 1-4  
mating plane, 3-3  
visual, 3-3  
isopropyl alcohol  
as cleaning solvent, 3-4

## K

kit  
contents, 1-2  
overview, 1-2  
return to Agilent, 5-3  
serial number, 1-6

## L

label  
calibration, 4-3  
part number, 6-5  
loads  
broadband, 1-2

## M

maintenance, 3-2  
preventive, 1-8  
making connections, 3-6  
manual  
part number, 6-5

mating plane  
connector, 3-5  
inspection, 3-3  
surfaces, 3-5  
mechanical specifications, 2-3  
modifying calibration kit definition files, A-2

## N

nitrogen, 3-4  
numbers  
serial, 1-6  
recording, 1-6

## O

offices  
contacting Agilent, 5-3  
open-end wrench, 1-3, 3-9  
part number, 6-5  
opens, 1-2  
ordering parts, 6-2

## P

part numbers, 6-2  
parts  
ordering, 6-2  
replaceable, 6-2  
required but not supplied, 6-2  
performance verification, 4-2  
fail, 5-2  
permanently stored calibration definitions, 1-3  
pin depth  
typical values, 2-3  
preventive maintenance, 1-8

## R

recertification, 4-3  
how often?, 4-3  
interval, 4-3  
what's included, 4-3  
where to send your kit, 4-3  
regulations  
environmental, 3-5  
replaceable parts, 6-2  
requirements  
environmental, 2-2  
return loss  
specifications, 2-4  
return, kit or device, 5-3

## S

sales  
contacting Agilent, 5-3  
serial numbers, 1-6  
devices, 1-6  
recording, 1-6  
service, 5-2  
contacting Agilent, 5-3  
service tag, 1-4, 4-3, 5-3  
sex, connector, 1-8

- shipment
  - damage, [1-4](#)
  - verifying complete, [1-4](#)
- shorts, [1-2](#)
- specifications, [2-2](#)
  - altitude, [2-2](#)
  - certification, [2-4](#)
  - distance from ref plane to shorting plane, [2-3](#)
  - electrical, [2-4](#)
  - environmental, [2-2](#)
  - frequency, [2-4](#)
  - humidity, [2-2](#)
  - inside diameter of outer conductor, [2-3](#)
  - mechanical, [2-3](#)
  - return loss, [2-4](#)
  - temperature, [2-2](#)
  - verifying, [4-2](#)
- standard definitions
  - downloading from Agilent Web site, [A-2](#)
- standards
  - calibration, [2-4](#)
  - NIST, [2-4](#), [4-3](#)
- static discharge, [3-2](#)
- sticker
  - calibration, [4-3](#)
- storage, [3-10](#)
  - altitude, [2-2](#)
  - temperature, [2-2](#)
- supplies
  - cleaning, [1-3](#)

## T

- tag
  - service, [1-4](#), [4-3](#), [5-3](#)
- temperature
  - calibration, [2-2](#)
  - device, [2-2](#)
  - error-corrected temperature range, [2-2](#)
  - measurement, [2-2](#)
  - operating range, [2-2](#)
  - verification and measurement, [2-2](#)
- test data, [4-2](#)
- threads
  - connector, [3-4](#)
- torque wrench, [1-3](#), [3-6](#)
  - part number, [6-5](#)
  - specifications, [3-6](#)
- traceability, [4-2](#)
- troubleshooting, [5-2](#)
- two-piece female open, [3-9](#)

## V

- verification
  - performance, [4-2](#)
  - temperature, [2-2](#)
- visual inspection, [3-3](#)

## W

- warranty, documentation, [-ii](#)